



# E27/E40 LED Round Retrofit Kit

## BRIGHTEN YOUR LIFE

NEW LED TECHNOLOGY THAT ALLOWS THE  
COEXISTENCE OF ENVIRONMENTAL  
PROTECTION AND ENERGY SAVING

### Benefits

1. MH/HPS/HID/MHL/CFL lamp retrofit
2. Screw Base Direct Install by bypass ballast
3. 100% Die Casting Heat Sink
4. Universal Base E26/E27/E39/E40
5. ETL CETL CE ROHS listed



BB-SDD-XXXD1

## Features

1. Beam angle:120 degrees.
2. Aluminum fins heat sinks and active air exchanging cooling system in order to speed up heat dissipation.
3. It's major to replace the CFL/MH/HID/HPS.
4. Green, energy saving, long and reliable life of 50,000 hours.
5. No RF interference, No IR/UV radiation ,no mercury pollution.
6. Wide colour availability in degrees Kelvin(K),2700-6700K.
7. Streamline exterior design, beautiful appearance.
8. Environment friendly ,energy saving (70~80%).
9. Special circuit design, each LED work separately, avoiding the single broken LED influence problem.
- 10.New temperature protection module.

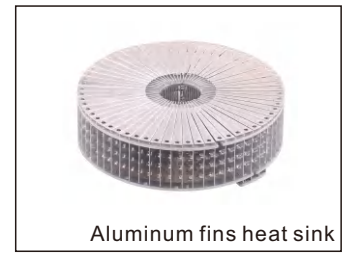

## Application

- 1.Area Light/Shoesbox Light.
- 2.Wall Pack Light/Sports Light/Post Top Light.
- 3.Canopy Light/Garage Light/Ceiling Light.
- 4.Flood Light/Pole Light.
- 5.High/Low Bay Light.
- 6.Roadway Light/Street Light/Billboard Light.

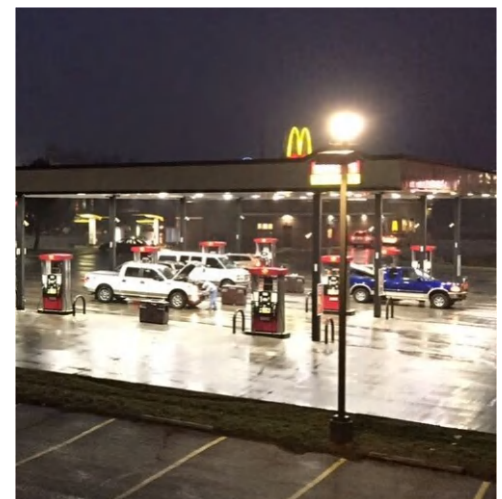

# SPECIFICATIONS

Power	60W	80W	100W	120W	150W	240W	300W
Model	BB-SDD-60WD1	BB-SDD-80WD1	BB-SDD-100WD1	BB-SDD-120WD1	BB-SDD-150WD1	BB-SDD-240WD1	BB-SDD-300WD1
Luminous Flux	7800lm	10400lm	13000lm	15600lm	19500lm	31200lm	39000lm
Replacement	HPS 200W	HPS 250W	HPS 300W	HPS 400W	HPS 600W	HPS 700W	HPS 1000W
DLC certification (only -E39)	Y	Pending	Y	Pending	Y	Y	Y
	BB-SDD-150WD1-HV&BB-SDD-300WD1-HV						
Light Source	SMD LED						
Luminous Efficacy	>130lm/w						
Operation Temp.	-40 to +45°C						
CCT	2700K SW / 3000K WW / 4100K NW / 5000K DW / 5700K CW						
CRI	80+						
Life Span	50,000 hours at 25°C						
Voltage	(BB-SDD-XXX)100-277VAC/50-60HZ (BB-SDD-XXX-HV)200-480VAC						
Driver	UL listed dimmable power supply						
Dimming	3 in 1 Dimming Driver(1-10VDC,10V PWM signal ,resistance)						
Beam Angle	120°						
Lamp Base	E26/E27/E39/E40						
Bracket Optional	Option: L-shaped bracket						
PF	>0.95						
Warranty	5Years						

# DIMENSIONAL DRAWING

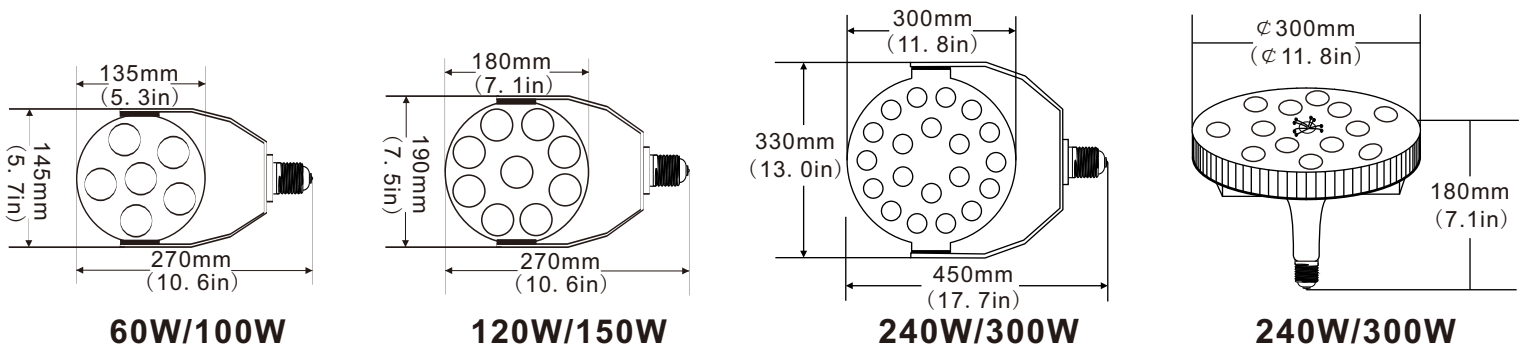

# LUMINOUS INTENSITY DISTRIBUTION

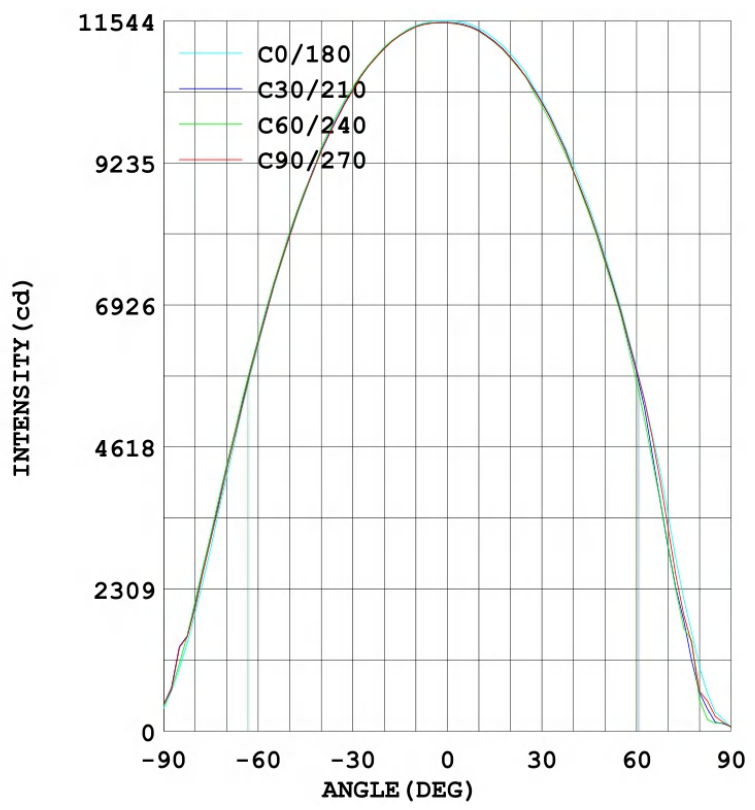
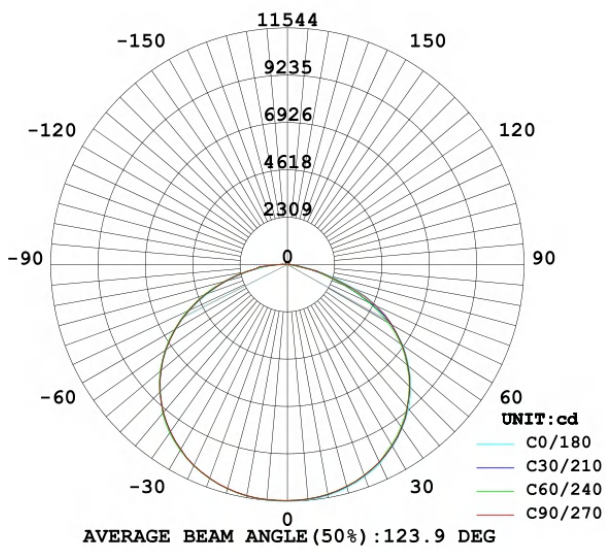

# PROJECTS

By using our 100W E40 retrofit kit to replace 300W Metal Halide bulb for outdoor parking lot shoebox fixtures, the customer is now able to save a lot per month from his electric bill.

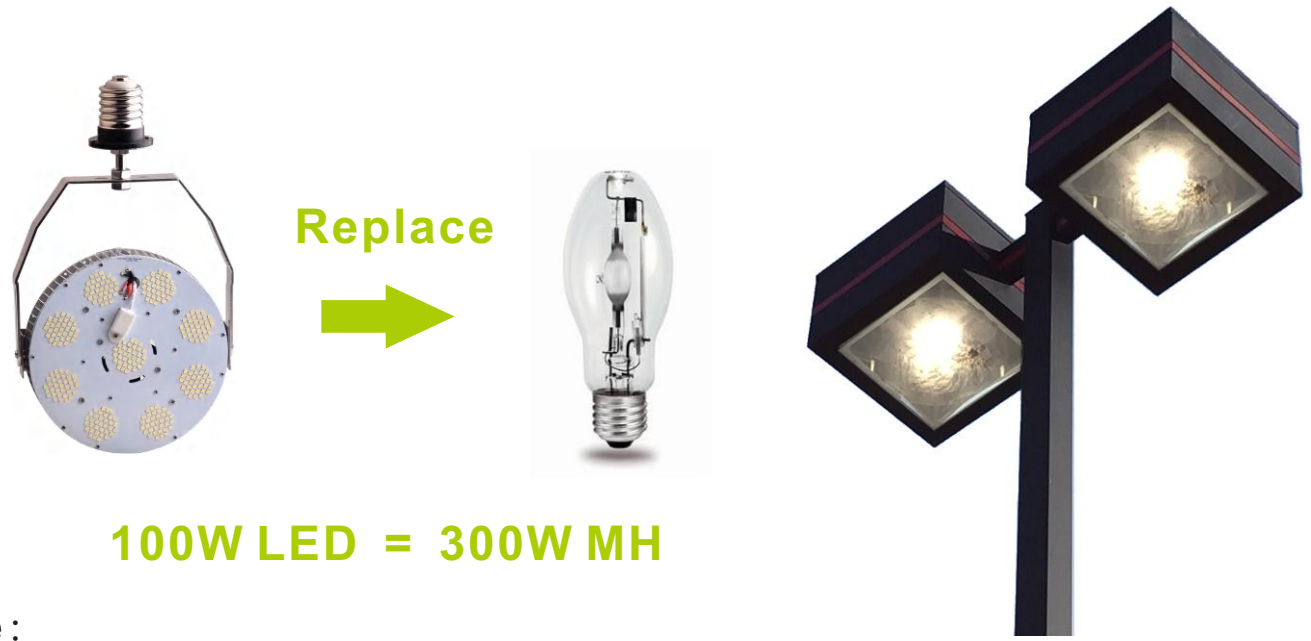

**100W LED = 300W MH**

### Note:

- Don't take the LED lamp apart.
- The LED lamp must work under the right voltage according to the specification.
- Must remove the Ballast, Capacitor, Ignitor before installing our LED Light.

# INSTALLATION

Normally. The traditional lamp has the ballast or capacitor or ignitor, like HPS, MH.

## Replace E40/ E27 CFL

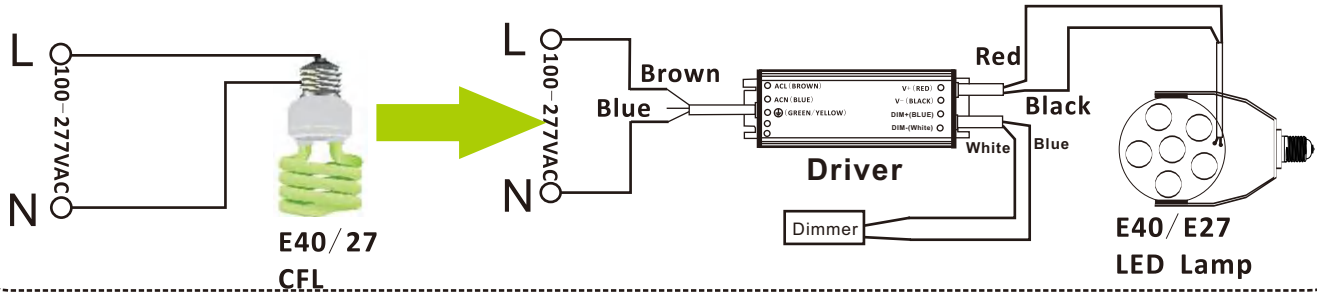

## Replace HPS/MH

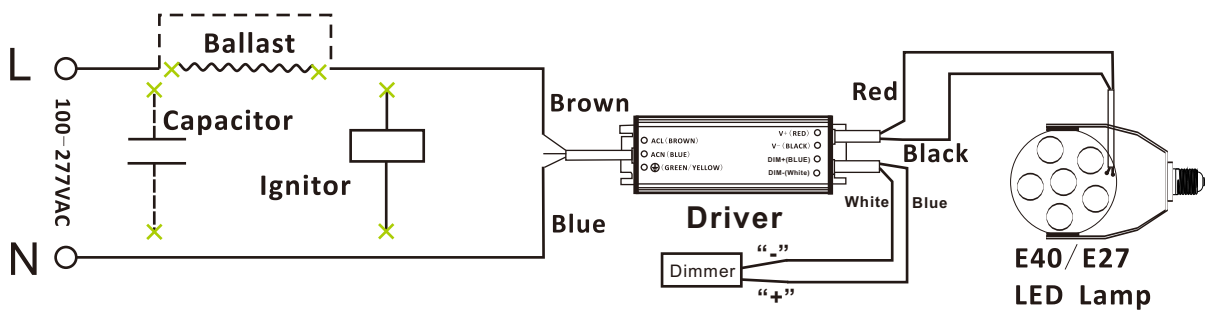

1. Remove the Ballast, Capacitor, Ignitor
2. Only need to put the L (live wire), N (null line) connected to the external power supply

Please notice the Lamp you received have to connect the External Driver (like above) before you turn on the Power (Electricity)!! Otherwise the lamp will Buming-out if you don't connect the External Power Supply!!

100-277VAC Input

ACL (Brown)  
ACN (Blue)  
Green/Yellow It's For Ground Electrode



Driver

V+ (Red)  
V- (Black)  
DIM+ (Blue)  
DIM- (White)

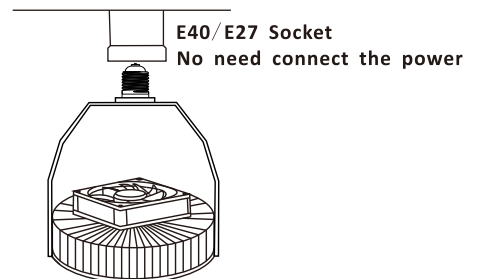

# L-SHAPED BRACKET



L-shaped bracket

## Installation

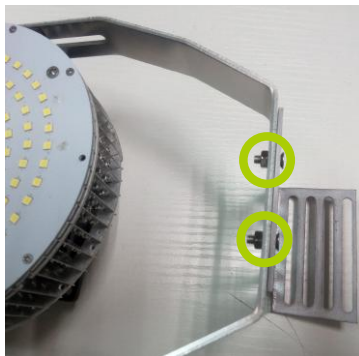

1. Adjust the bracket angle to your own needs, fixed bracket tightly. Then follow your own need to select the appropriate holes in the L-shaped bracket, the L-shaped bracket fixed on the bracket with two screws.

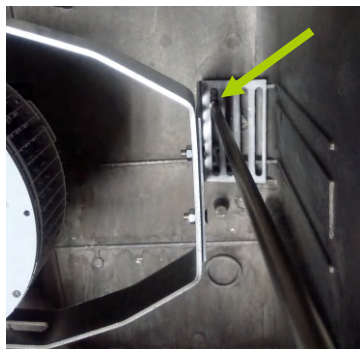

2. Follow your own need to select the appropriate holes in the L-shaped bracket, the L-shaped bracket fixed inside the lamp housing with two screws.



3. Make sure that the lamp firmly fixed and completed.

# PACKING INFO



Items	Packaging unit	Carton Size(mm) (L*W*H)	N.W	G.W	Volume weight
60-100W	12pcs/CTN	700*590*370mm	15.9kg	17.3kg	31.0kg
120-150W	12pcs/CTN	700*590*370mm	26.6kg	28.0kg	31.0kg
200-300W	3pcs/CTN	520*380*390mm	12.1kg	13.5kg	16.0kg