

## LED SHOE BOX LIGHT

UNIQUE SPECIAL DESIGN  
HIGH BRIGHT LED CHIPS  
VARIOUS ADJUSTABLE MOUNT  
UL CUL DLC CERTIFIED  
SMART LIGHTING

### Features

- 100-320W Available
- Dust-proof and waterproof
- UL,cUL,DLC approved
- Dusk to Dawn photocell sensor
- Microwave motion sensor
- Die-cast aluminum housing anti-corrosion
- Silicone rubber seal, moisture, high temperature.
- 6K High voltage Surge test approved.
- SMD3030 130LMW LED chips
- 50,000hrs lifespan
- 100-277VAC,185--528VAC input voltage
- All in one(Round,square pole),slip fter,Trunnion choice.
- Beam angle : TYPE II TYPE III TYPE V
- 5 years warranty



Photocell

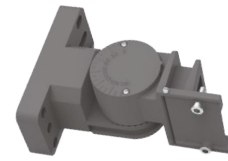

All in one(Round,Square)



Microwave motion sensor

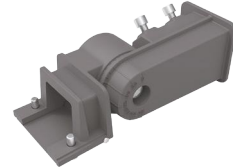

Slip Fitter



### Applications

LED Shoebox lighting series can be widely used in urban roads,Industrial areas,Residential areas, Sidewalks,Parking lot,Schools,Gardens and etc.



Series	Lumens	Base	Beam Angle (Degree)	Electrical Data	LED Type	Color temperature	Color rendering index
SB - 100W	14000LM	3 pin wires	TYPE II TYPE III TYPE V	Input Voltage 100-277VAC 50/60Hz 185-528VAC	SMD3030 chips	WW 3000K NW 4000K DW 5000K CW 5700K	70 70 CRI 80 80 CRI 90 90 CRI
SB - 150W	21000LM	3 pin wires		Total Power 100W 150W 200W 240W 320W			
SB - 200W	28000LM	3 pin wires		Power Factor(%) >90			
SB - 240W	33600LM	3 pin wires					
SB - 320W	44800LM	3 pin wires					

# DIMENSIONS

## 100W 150W 200W

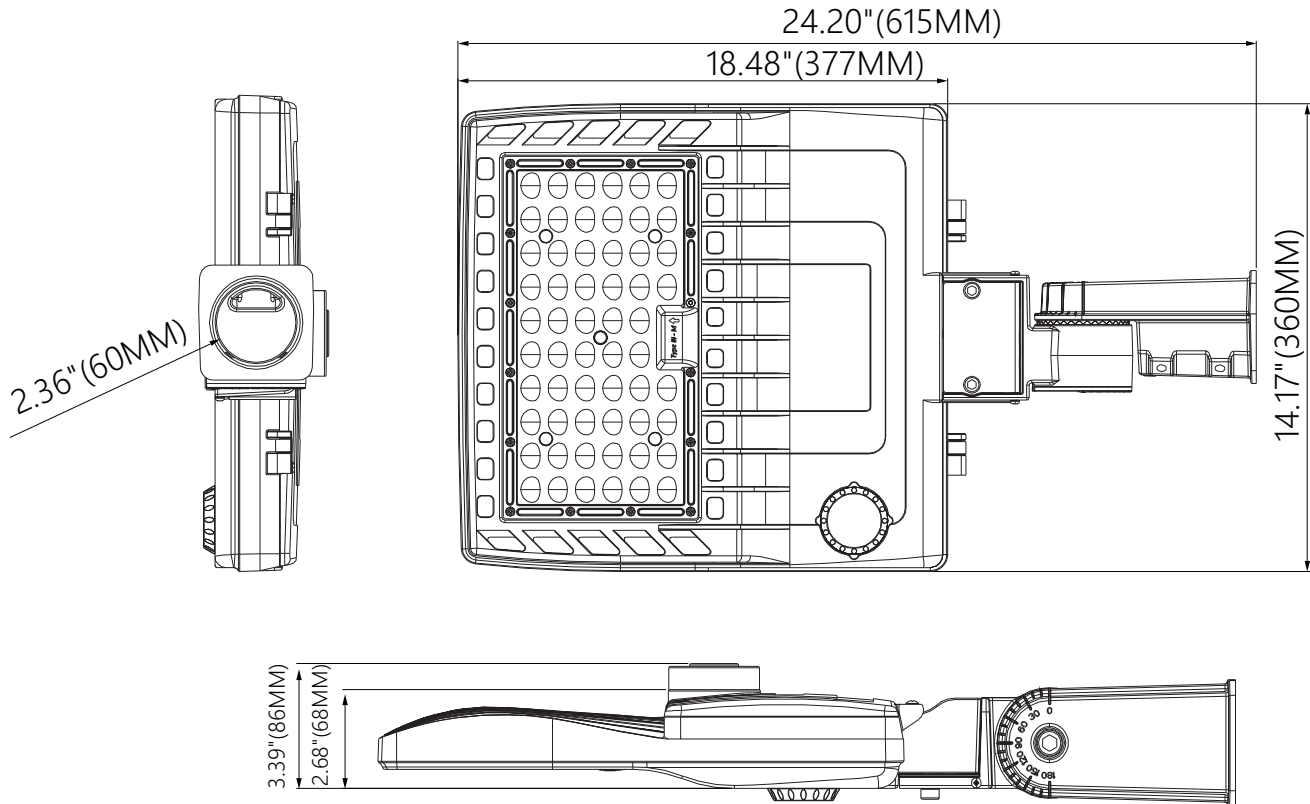

## 240W 320W

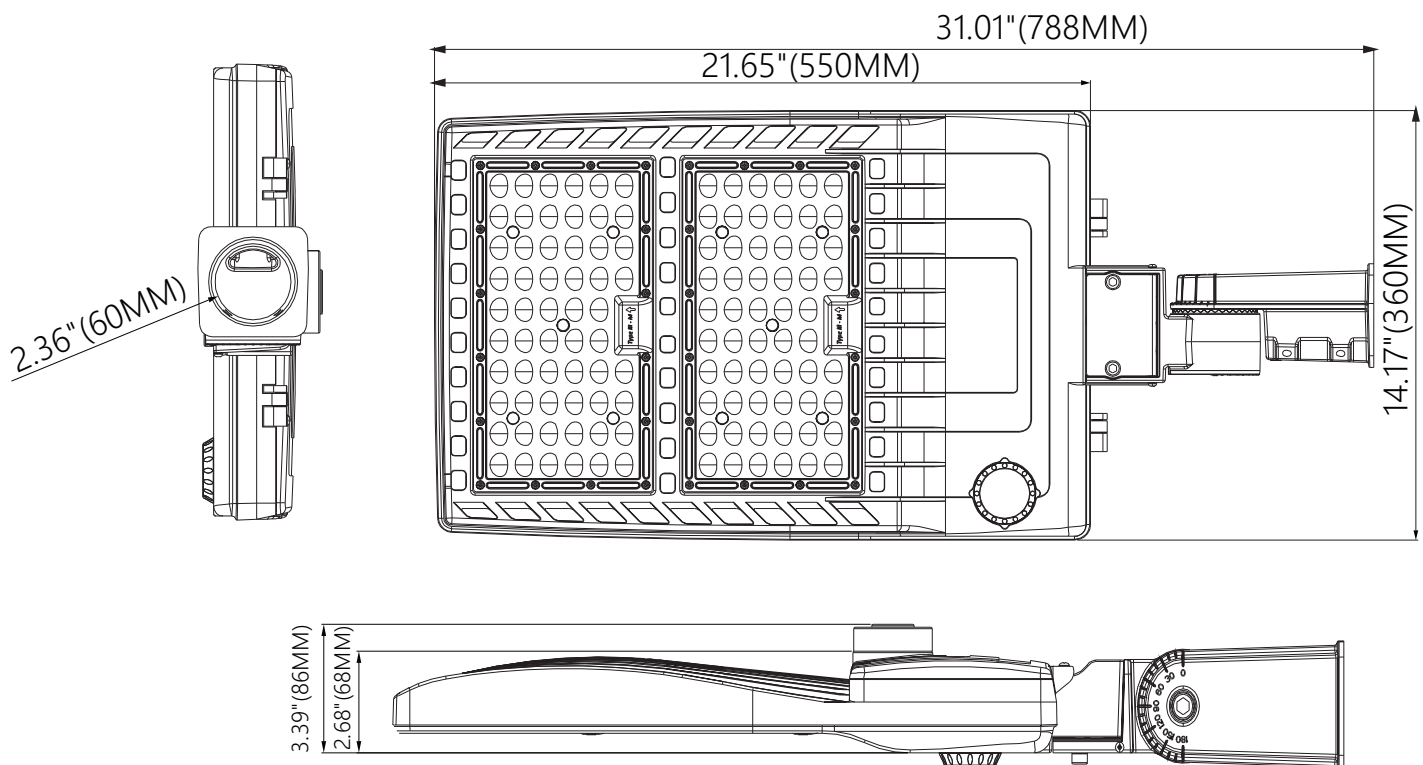

## TYPE III (100W)

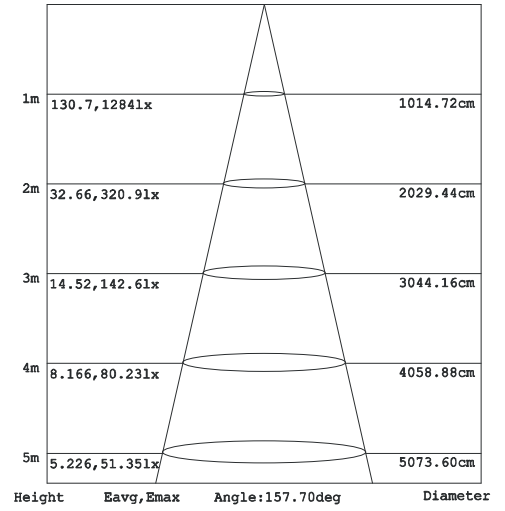
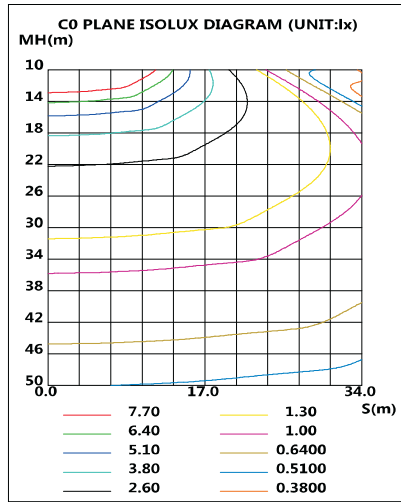
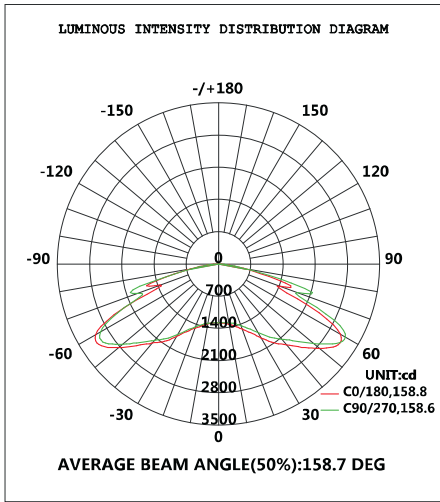

## TYPE III (150W)

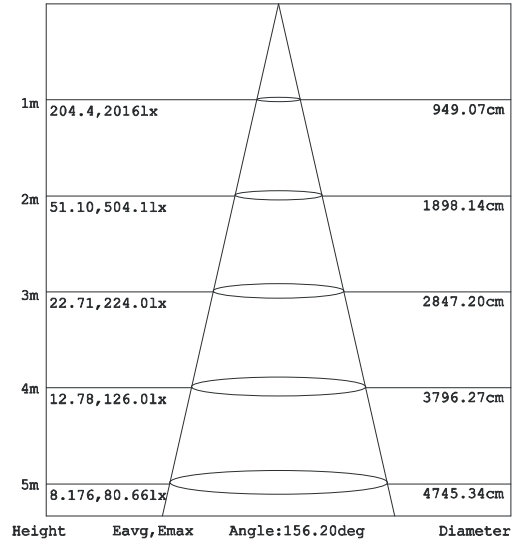
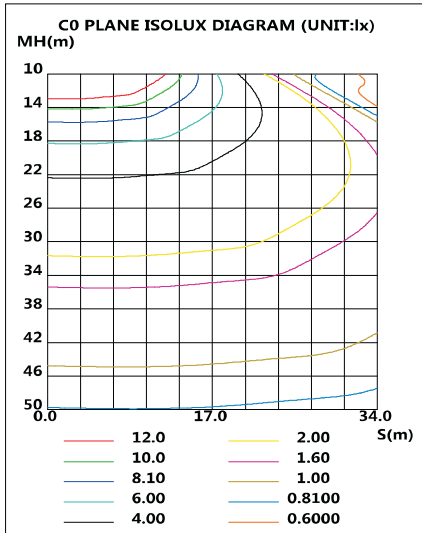
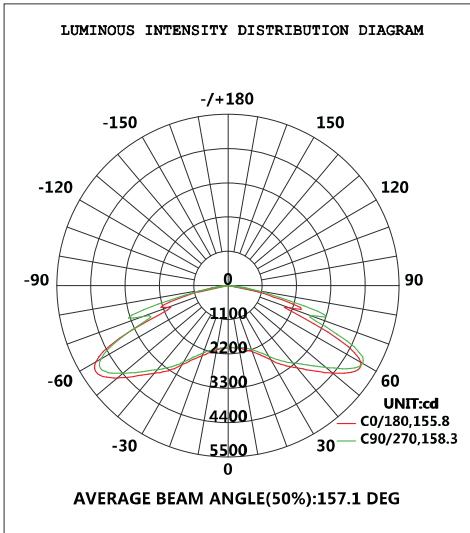

## TYPE III (200W)

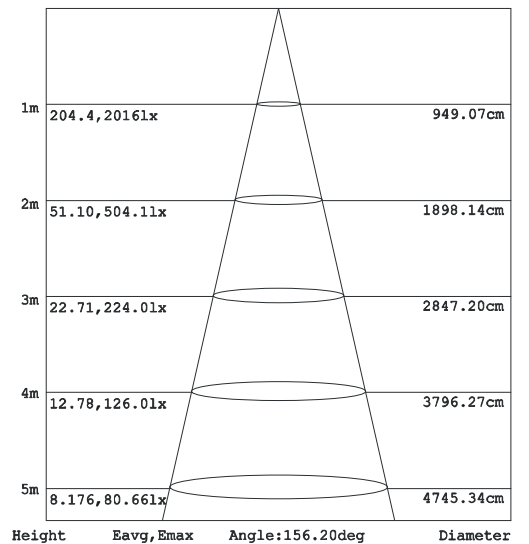
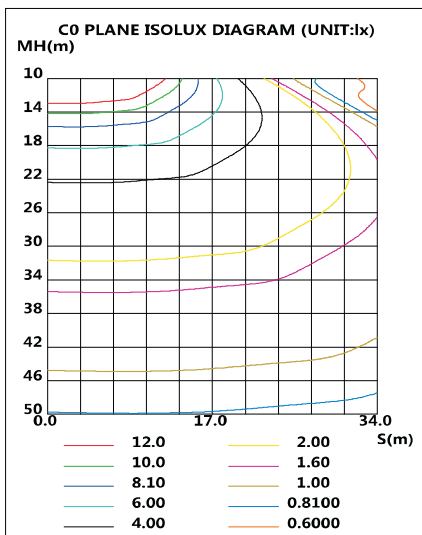
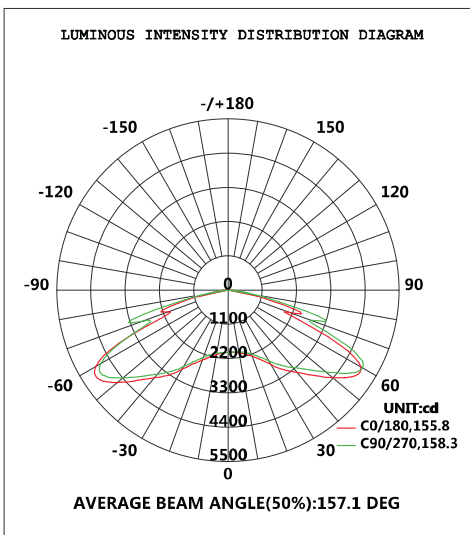

## TYPE III (240W)

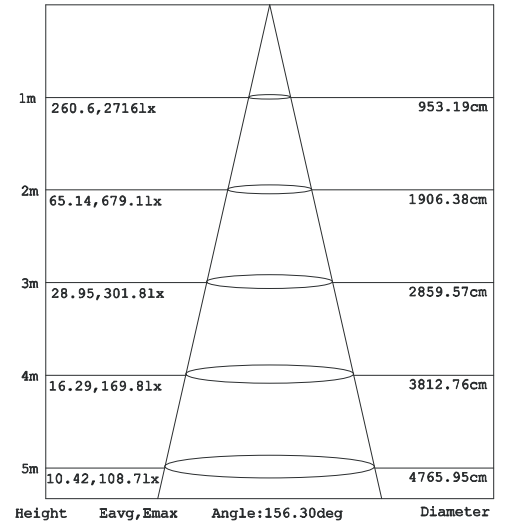
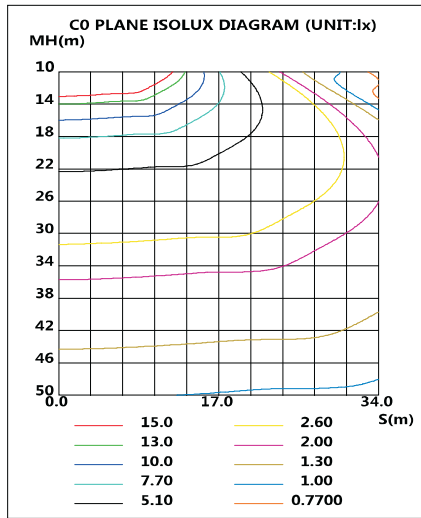
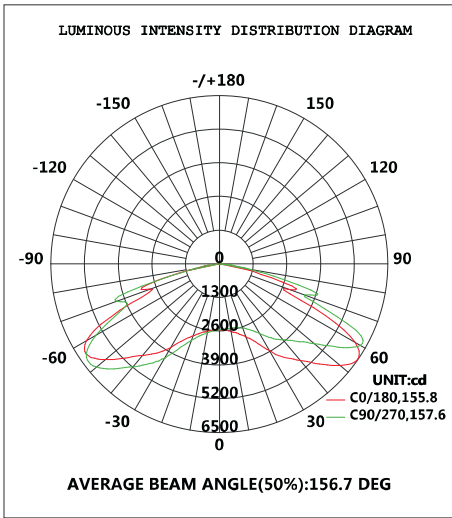

## TYPE III (320W)

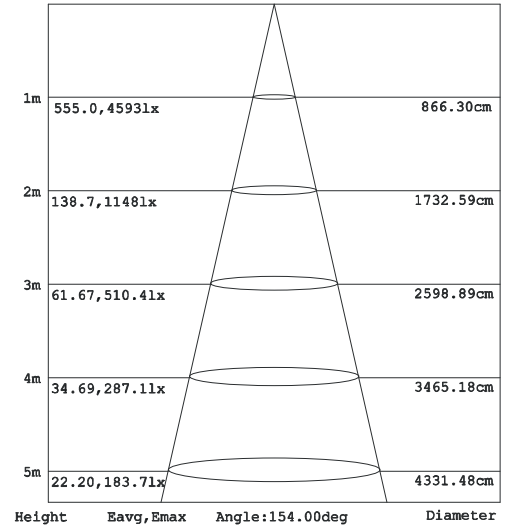
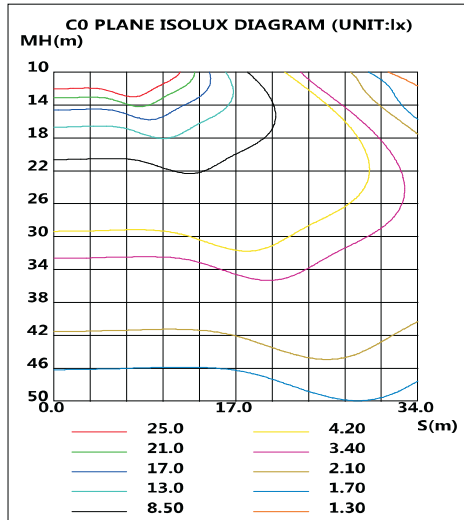
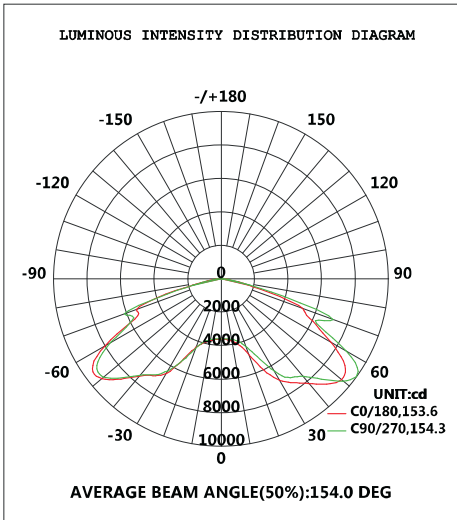

## Installation Instruction

**\*Warning: Do cut off electrical source in order to avoid electrical shock and endanger life-safety before installation.**

**\*Install height from floor high than 1.2m.**

Step 1:

Start installation of the street light  
turn the street light to the back side

Step 2:

Connect the cables  
Connect the L,N,GND cables on the lamp to the corresponding L,N,GND cables on the lamp pole.

Step 3:

Fixation of the LED Street lights  
Install the street light to the lamp pole, adjust the LED street light to be of horizontal level.

### 1. Slip Fitter

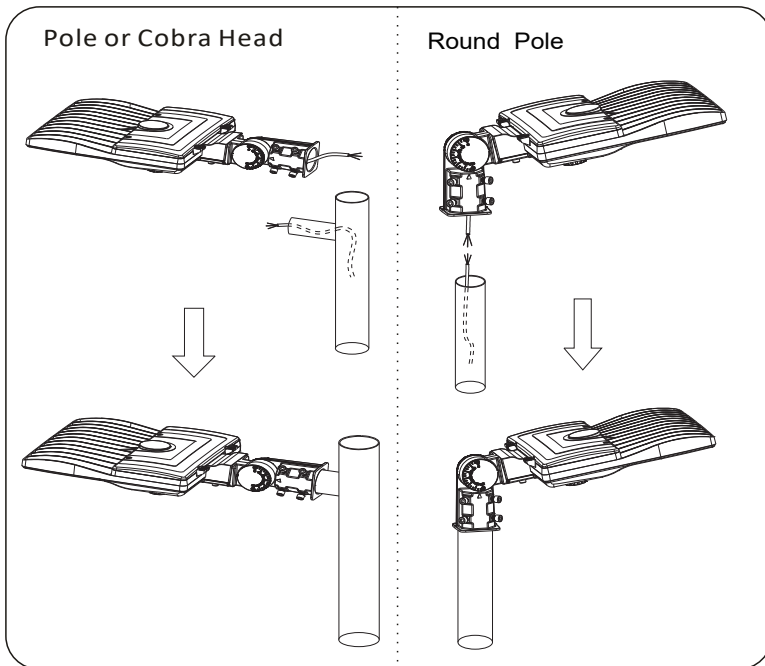

### 2. Arm

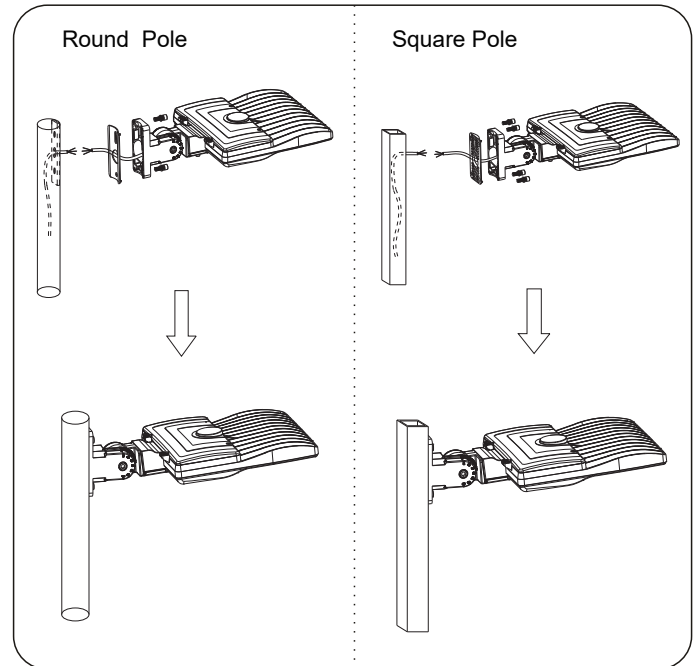

## Packaging

No.	Model	Power	N.W.	Inner Box	G.W	Qty/ctn	Outer Carton
1	SB - 100W	100W	6.2Kg	—	7.0Kg	1	26.57"x15.94"x6.49" (675x405x165mm)
2	SB - 150W	150W	6.2Kg	—	7.0Kg	1	26.57"x15.94"x6.49" (675x405x165mm)
3	SB - 200W	200W	6.2Kg	—	7.0Kg	1	26.57"x15.94"x6.49" (675x405x165mm)
4	SB - 240W	240W	9.1Kg	—	10.2Kg	1	33.27"x15.94"x6.49" (845x405x165mm)
5	SB - 320W	320W	9.1Kg	—	10.2Kg	1	33.27"x15.94"x6.49" (845x405x165mm)