

LED Work String Light

NS-SWL10-05
NS-SWL10-10

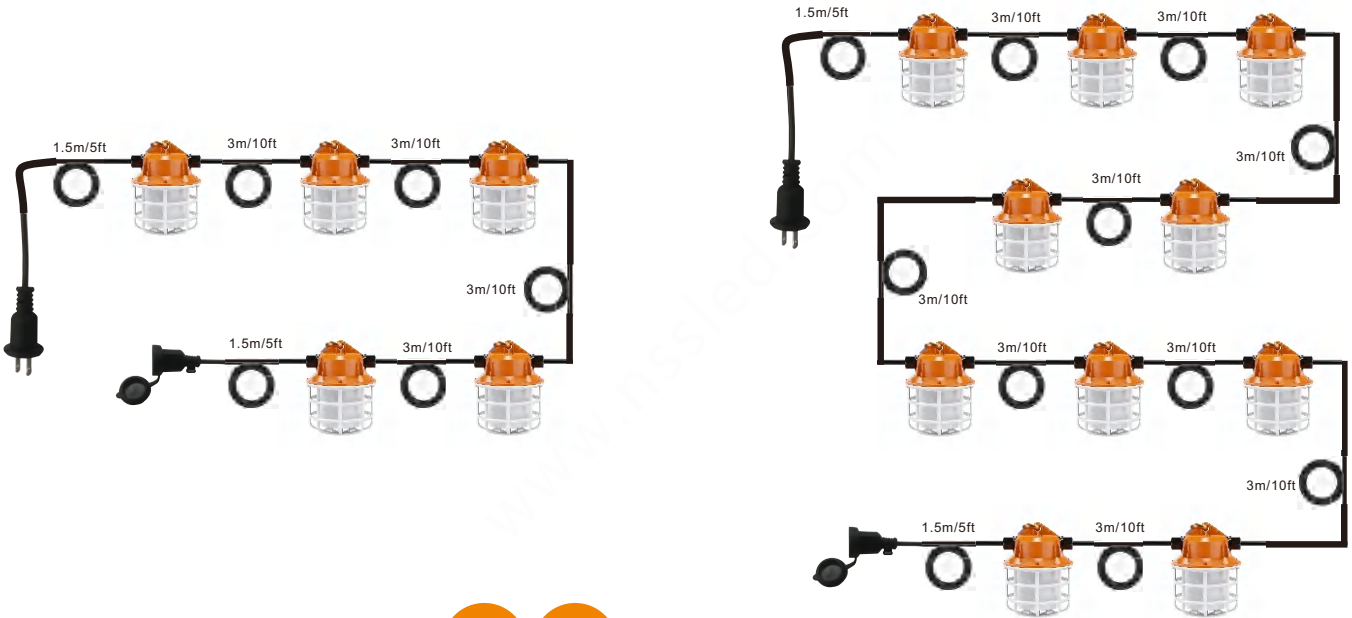

Applications

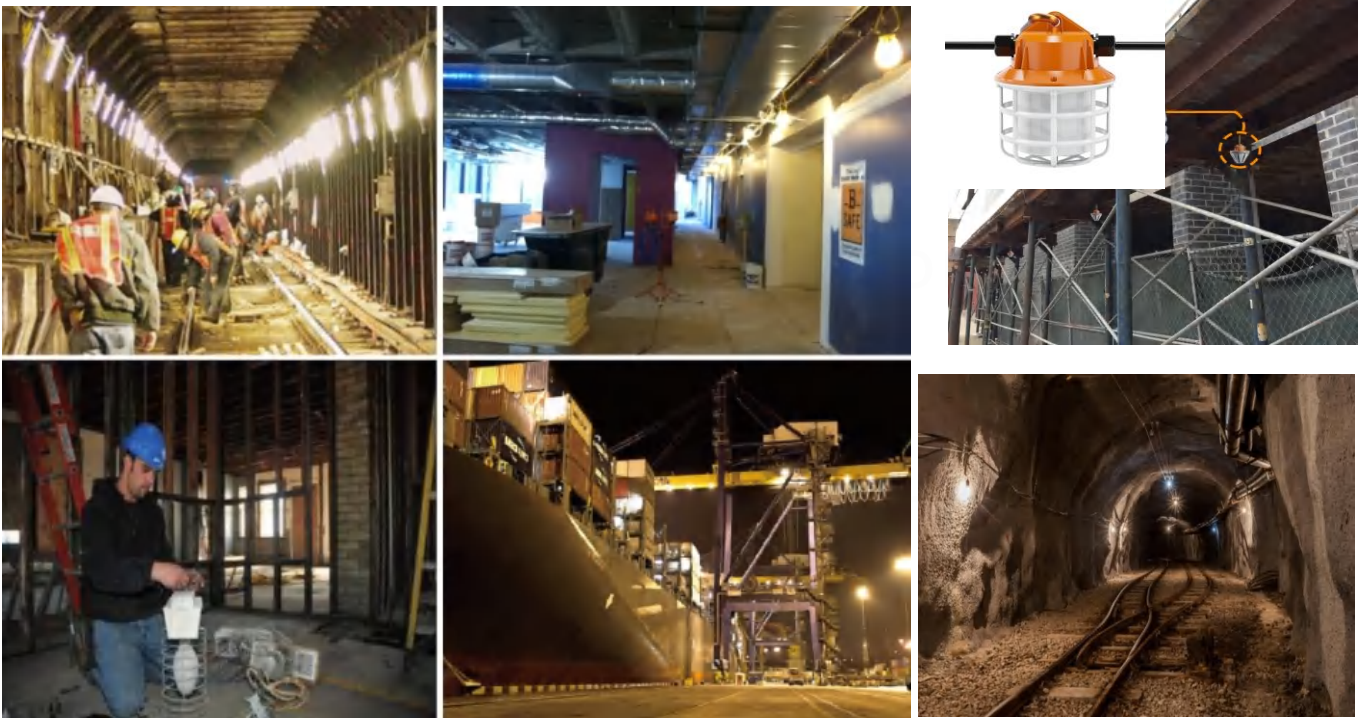

Features

- 360-degree luminescence, Explosion-proof and pressure-resistant design of the cover.
- Wide voltage constant current power supply, high efficiency, no flicker.
- Portable hooks are convenient, flexible and easy to operate.
- Waterproof plug and socket connectors available.
- Suitable for outdoor wet or humid places. IP65 waterproof rating.

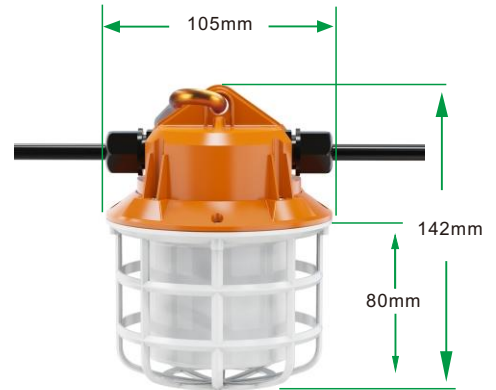

Parameter

Model	Power	Lumens (LM)	Voltage	Base	CCT(K)	Dim.	CRI	SMD	Weight	IP rate
NS-SWL10-05	50W	5000LM	100-277VAC	Pothook	3000-6500K	φ105*142 mm φ4,1*5,6 in	>80	2835	1.8Kg	Ip65
NS-SWL10-10	100W	10000LM	100-277VAC	Pothook	3000-6500K	φ105*142 mm φ4,1*5,6 in	>80	2835	3.2Kg	Ip65

Logistical Data

Package

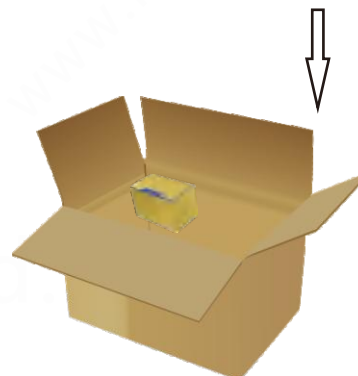
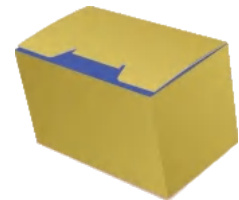
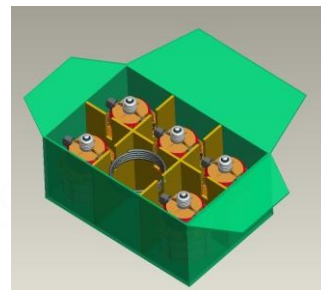
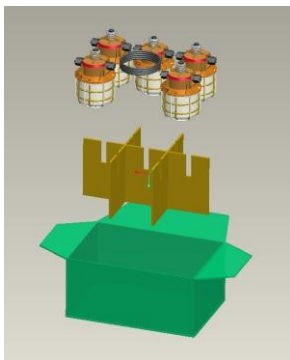

Packing list	
Finished product lamp	1string
instructions	1pcs
Pothook	5pcs

Model	Packaging unit (Pieces/Unit)	Dimensions	Gross weight	Volume
NS-SWL10-05	Small box 1	34.3*22.8*15cm	2Kg	0.012m ³
	Outer Carton 8	46.8*35.3*62cm	17Kg	0.1m ³

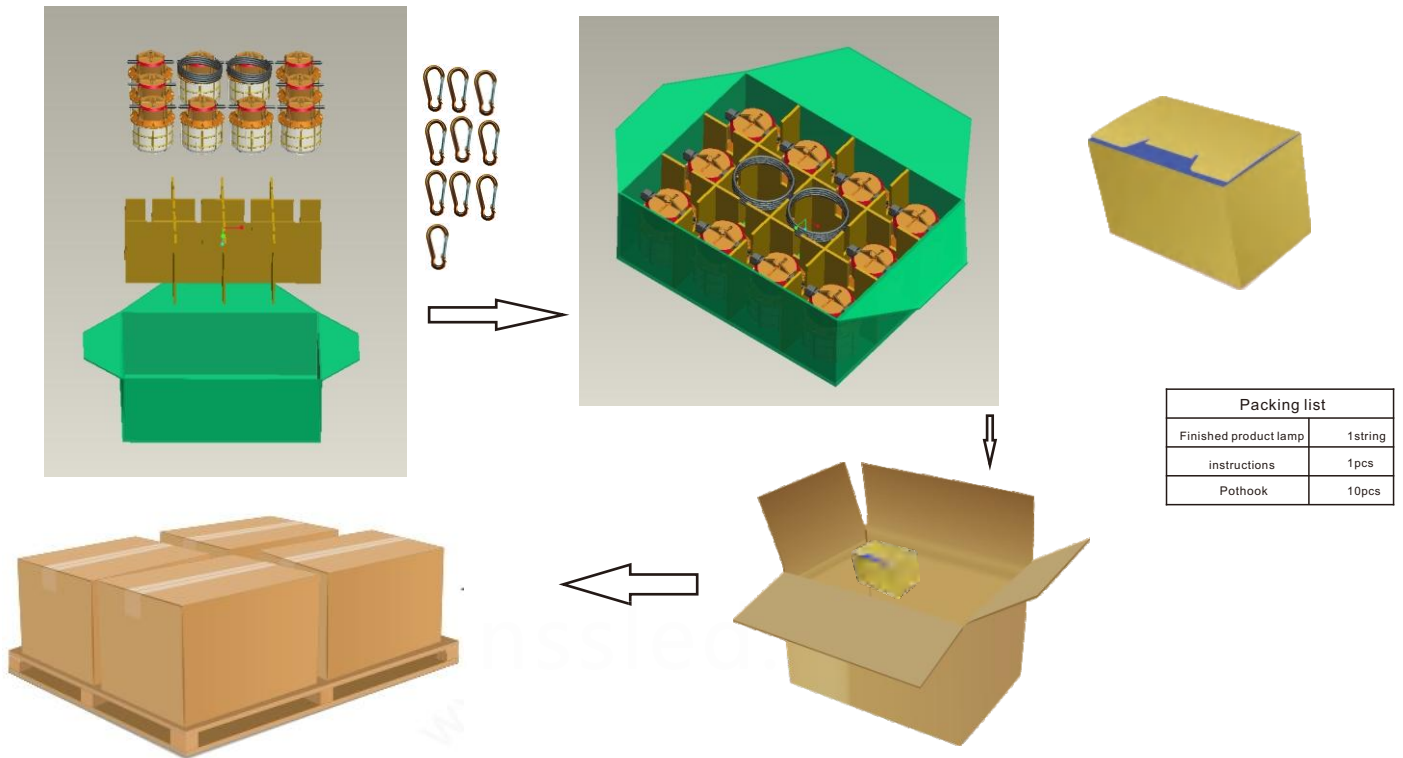

Packing list	
Finished product lamp	1string
instructions	1pcs
Pothook	10pcs

Model	Packaging unit (Pieces/Unit)	Dimensions	Gross weight	Volume
NS-SWL10-10	Small box 1	45.8*34.3*15cm	3.8Kg	0.023m ³
	Outer Carton 4	46.8*35.3*62cm	16.5Kg	0.1m ³

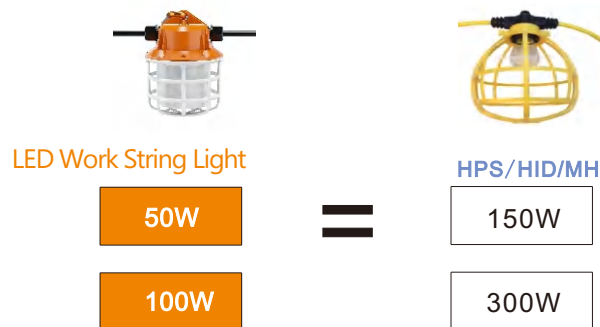

Additional product data

All technical parameters apply to the entire lamp/Due to the complex production process for light-emitting diodes, the typical values shown for the technical LED parameters are purely statistical values that do not necessarily match the actual technical parameters of each individual product, which can vary from the typical value.

Disclaimer

Subject to change without notice. Errors and omission excepted. Always make sure to use the most recent release.