

100-347Vac

8W/15W/20W/25W



EMERGENCY LED DRIVER

HIGH VOLTAGE OUTPUT
170VDC

CONSTANT POWER
EMERGENCY OUTPUT

Self Test

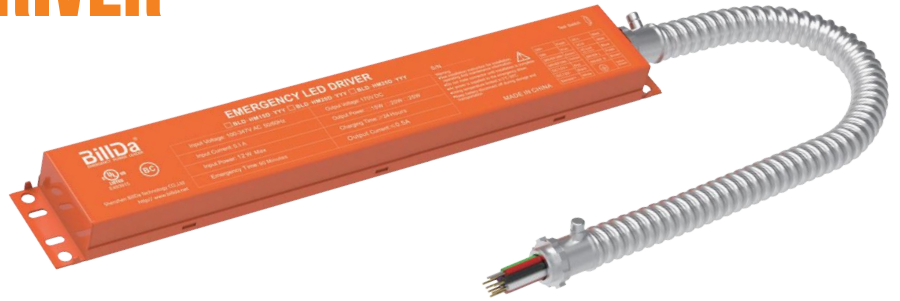

- CAUTION:**
- ① The Emergency LED driver must connect to 0/1-10V dimming wires(DIM+,DIM-) of the fixture if the LED luminaire power is exceed the emergency LED driver power.
 - ② In emergency mode, double-click this test switch to turn off the current emergency state.

"YYY"Maybe any number or letter or blank for sales purpose

MODEL NO.	BLD-HM08D-YYY	BLD-HM15D-YYY	BLD-HM20D-YYY	BLD-HM25D-YYY
Input Voltage	100-347Vac,50/60Hz	100-347Vac,50/60Hz	100-347Vac,50/60Hz	100-347Vac,50/60Hz
Input Current	0.1A max	0.1A max	0.1A max	0.1A max
Input Power	12W max	12W max	12W max	12W max
Output Voltage	170V DC	170V DC	170V DC	170V DC
Output Power	8W	15W	20W	25W
Application	≤80W(0-10V Dimmable Fixture) ≤8W LED Lamps without dimming function	≤150W(0-10V Dimmable Fixture) ≤15W LED Lamps without dimming function	≤150W(0-10V Dimmable Fixture) ≤20W LED Lamps without dimming function	≤150W(0-10V Dimmable Fixture) ≤25W LED Lamps without dimming function
Ambient Temperature	5℃~50℃	5℃~50℃	5℃~50℃	5℃~50℃

Wiring Diagram

Wiring 1 : For LED Driver With Input Power Higher Than Emergency Output Power

0/1-10V Dimmable LED Driver + Dimmer Switch

Emergency Driver Dim+(Green) , Driver Dim-(Yellow) Have to connect with LED driver DIM+ and DIM-

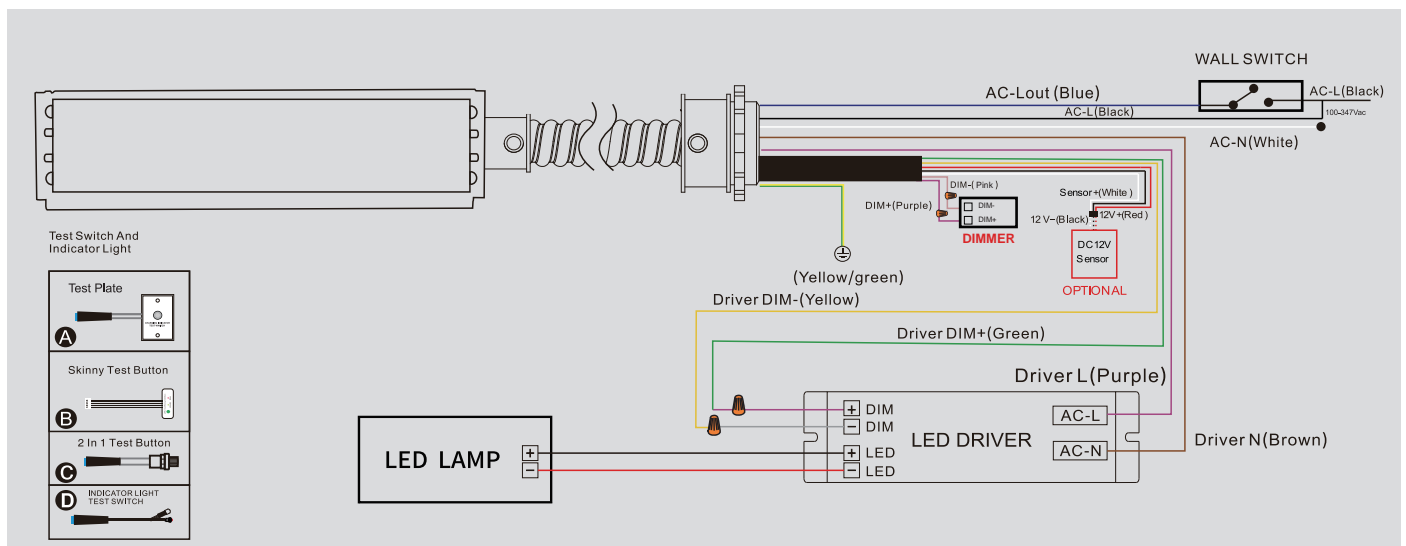

Wiring 2 : For LED Driver With Input Power Higher Than Emergency Output Power

0/1-10V Dimmable LED Driver + Wall Switch

Emergency Driver Dim+(Green) , Driver Dim-(Yellow) Have to connect with LED driver DIM+ and DIM-

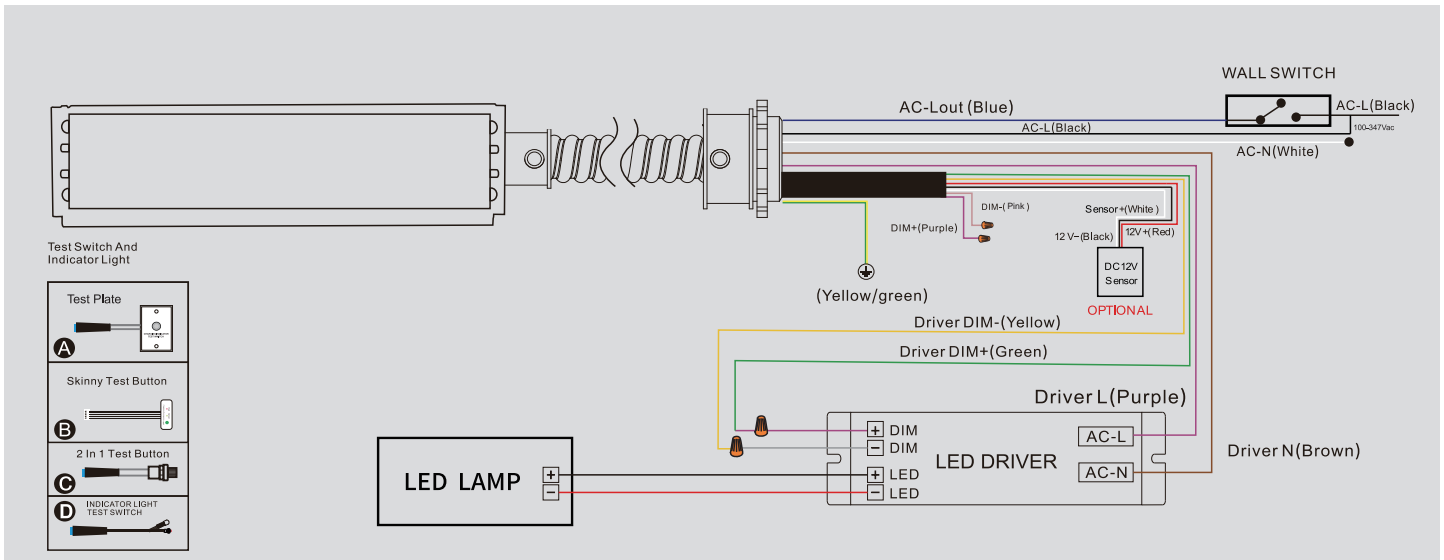

Wiring 3 : For LED Driver With Input Power Less Than Emergency Output Power

NON Dimmable LED Driver

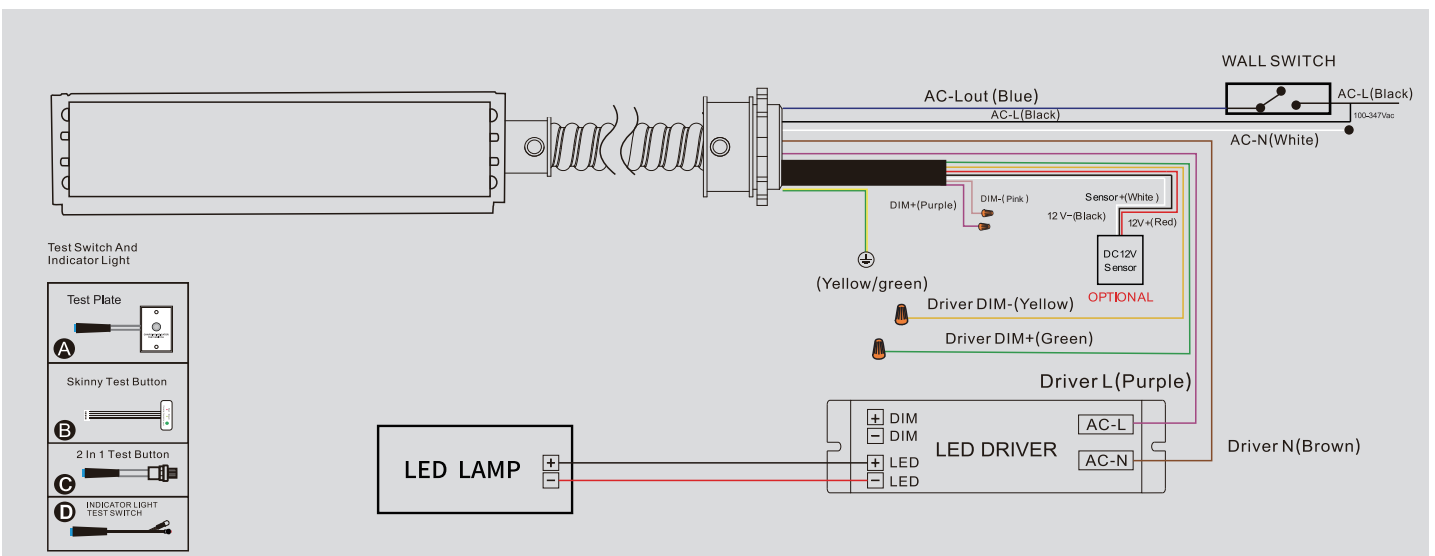

IMPORTANT SAFEGUARDS

When using electrical equipment, basic safety precautions should always be followed including the following

PLEASE READ AND FOLLOW ALL SAFETY INSTRUCTIONS.

CAUTION:RISK OF SHOCK-disconnect emergency and normal input power sources before servicing any equipment connected to this unit.

CAUTION:Risk of fire or electric shock-This emergency battery pack installation requires knowledge of luminaire and electrical systems.

CAUTION:Servicing of this equipment should be performed by qualified personnel only

CAUTION:Before installation, make certain the AC power to fixture is off.

CAUTION:Verify that all replacement lamp types marked on the installed luminaire are also identified as suitable for use with this emergency battery pack.

CAUTION:Suitable for use in 5°C -50°C ambient temperatures.

IMPORTANT: An unswitched AC power source is required (100-347 VAC, 50/60 Hz). This device is designed for fixtures listed for dry and damp locations.

IMPORTANT: Customers are advised to charge emergency LED driver 24 hours every 6 months during storage

CAUTION:Do not use outdoors. Do not mount near gas or electric heaters.

CAUTION:Equipment should be mounted in locations and at heights where it will not be subjected to tampering by unauthorized personnel.

CAUTION:The use of accessory equipment not recommended by the manufacturer may cause an unsafe condition The emergency battery pack is not for in an air-handling fixture.

CAUTION:Do not use this equipment for other than its intended use.