

LED parking lot light product specification

Type A section of the interface (for D60 diameter pipe)

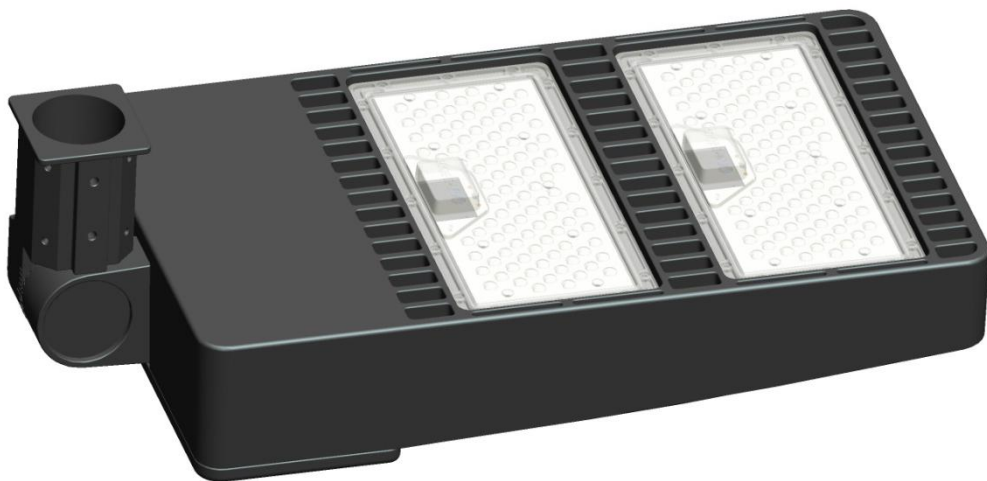

Type A2 section of the interface (for D76 diameter pipe)



Type B2 connector



Type C2 connector



Type D2 connector



Type E2 connectors



Type F2 connector



With light perception -P



I The application sites

Road lighting, car parks, residential roads.

II Product Features

1. Modular lens design, designed for parking lighting with light.
2. Hollow radiator design.
3. A variety of installation methods, rods can be formulated rod, and the angle is adjustable.
4. Beautiful appearance, lamp beads with 140LM / W Samsung LH351B lamp beads, the whole light efficiency 115LM / W.
5. Waterproof rating IP65.
6. Connectors are interchangeable, stocking easy to install.

III Product size

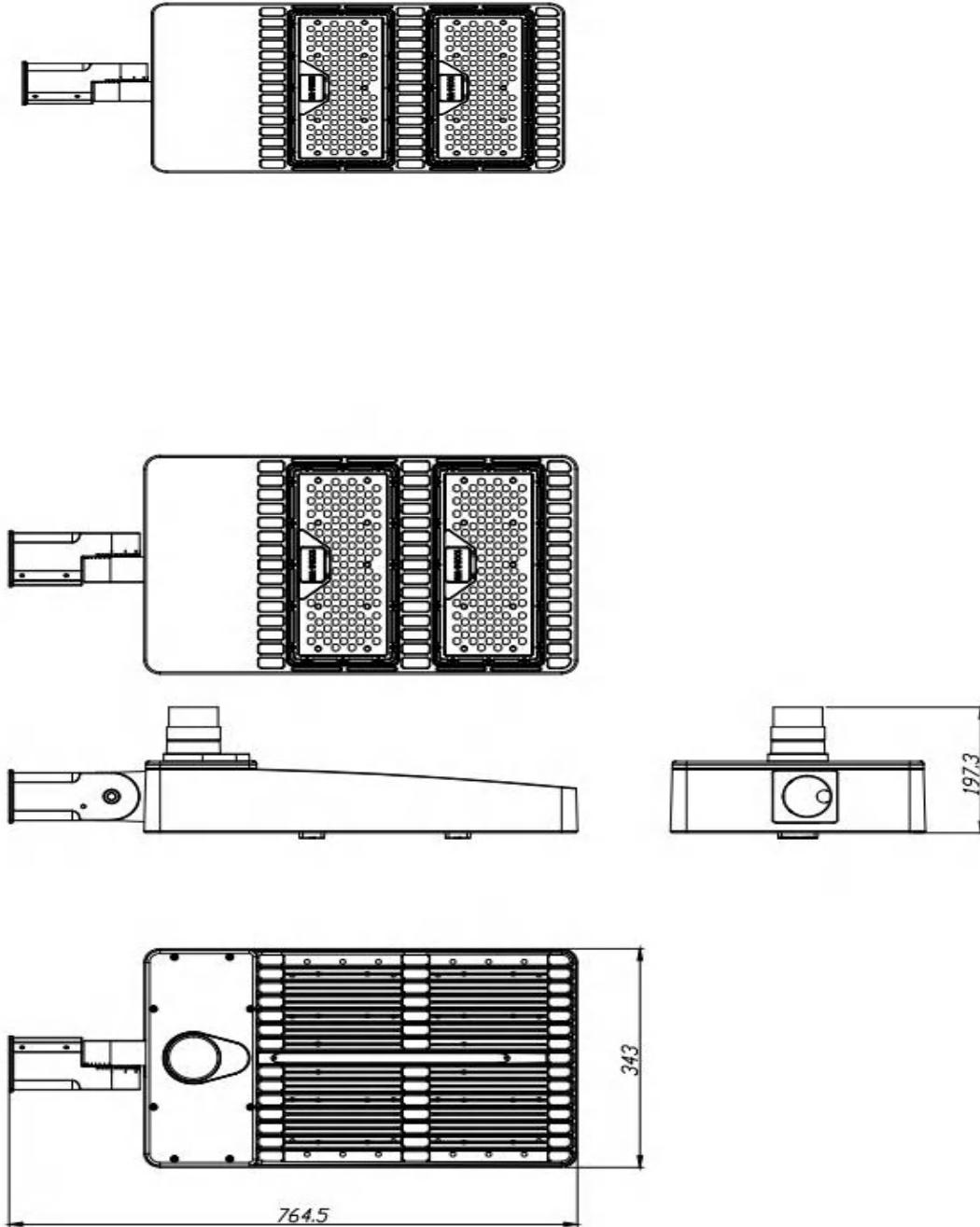

IV Performance parameters

model	Color temperature	CRI	Luminous flux	System power	Product Size / mm	LED Quantity	net weight

PL670D-W400	5000K	≥70	46000 lm	400±10W	764*343*112	180	18 KG
PL670D-W500	5000K	≥70	57000 lm	500±10W	764*343*90	180	18 KG
PL670D-W600	5000K	≥70	69500 lm	600±15W	764*343*112	200	18 KG
			I		* *		
LED: 180 pcs ,200 pcs							
3000K 4000K 5000K Color temperature optional							
AC 85V~305V							
Light distribution lens: TYPE IV (100*140)							
Power efficiency >0.9							
Operating temperature: -40 ~ 55°C							

V light distribution curve

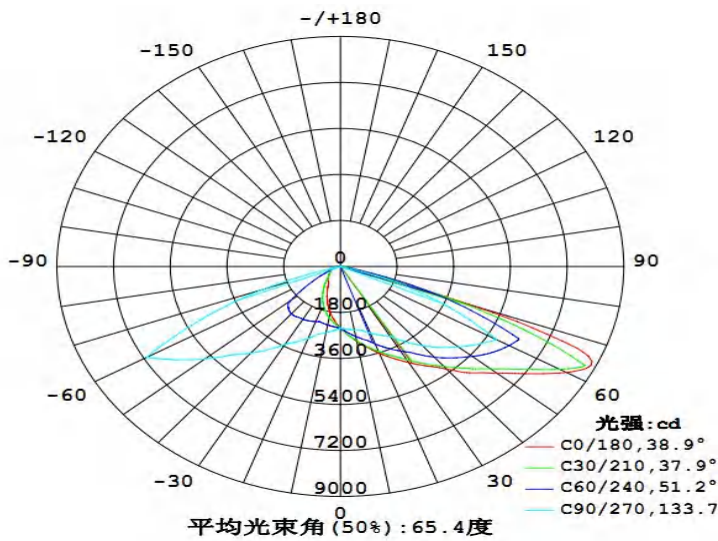

VI Installation Notes

Type A section connector (pole diameter ϕ 60mm)

Type A2 section of the connector (pole diameter ϕ 76mm)

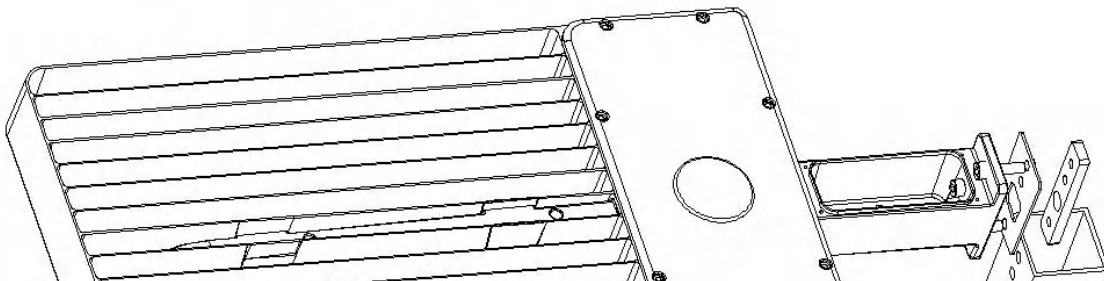

C2 connector (ring light pole diameter 60-114mm)

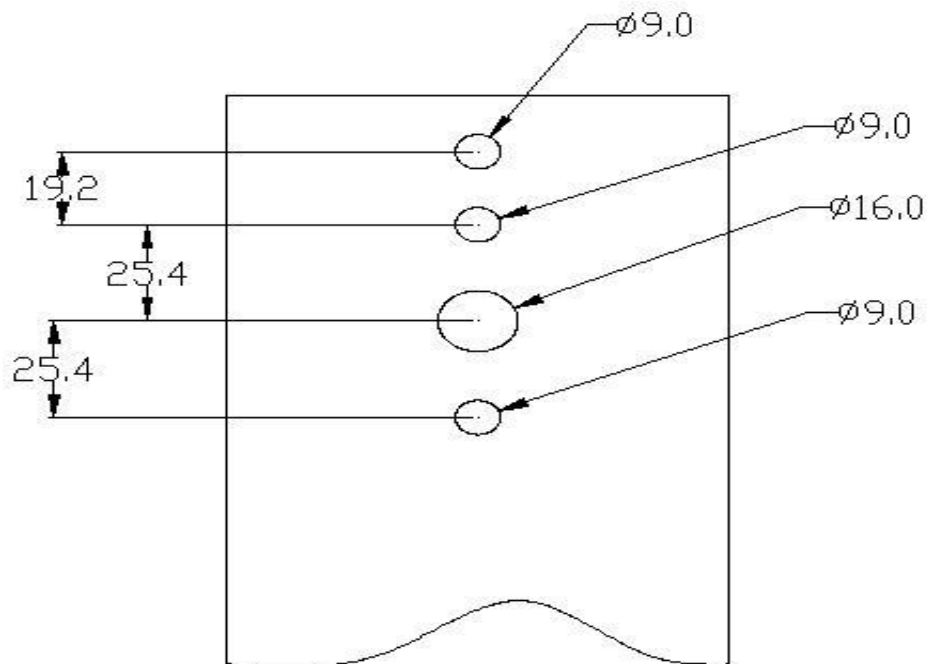
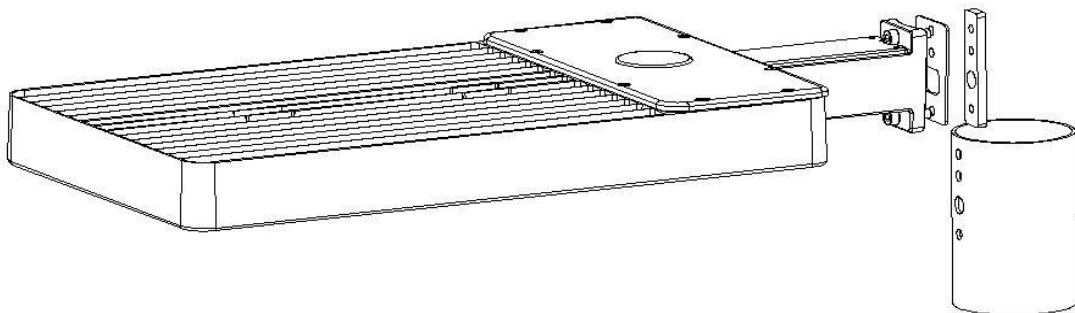
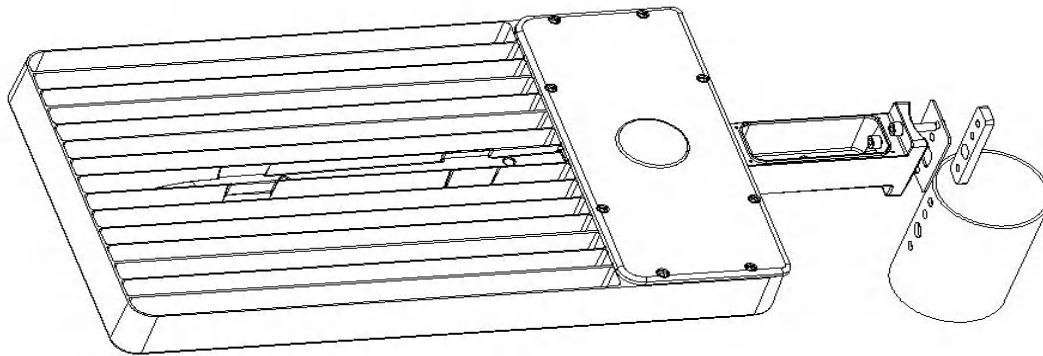

Fixed lamp tube hole position

D2 section of the connector (with square poles)

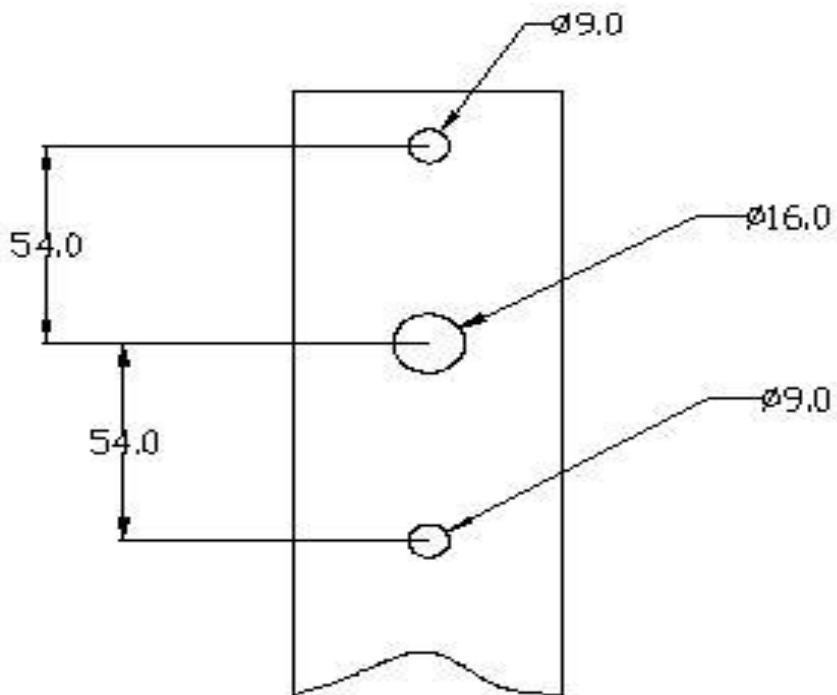
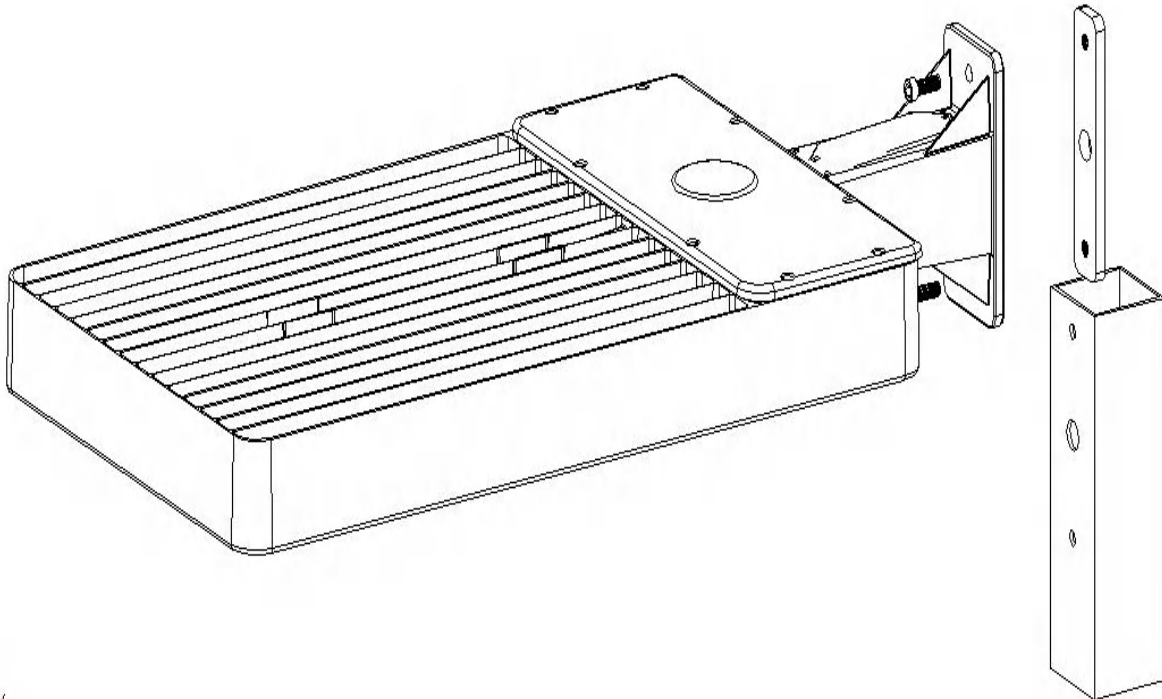

Fixed lamp square tube hole location

E2 connector (with circular light pole diameter 60mm-114mm)

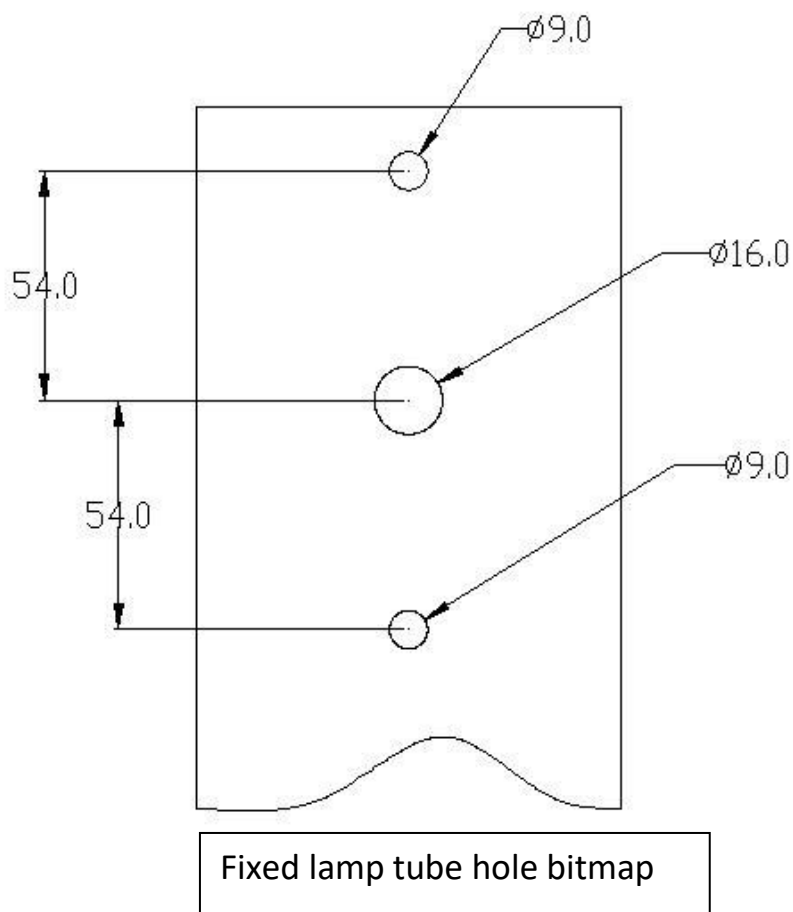
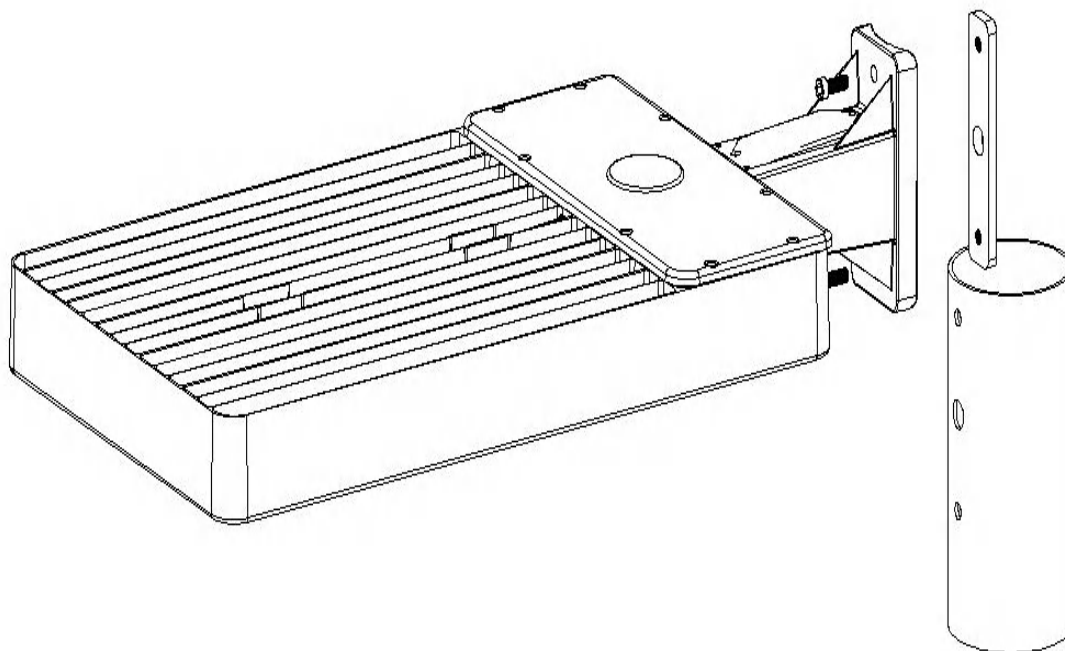

VII Installation Precautions

1. Turn off the power before installation and ensure that the installation site can withstand the weight of the lamp.
2. In order to prevent the lamp from falling off, be sure to make sure the installation is correct.
3. Do not use in areas where corrosive gases are present.
4. Do not cover any material on the body.
5. For safety, please grounded the ground.
6. The lamp from the date of purchase, warranty for five years.
7. However, failure to disassemble, modify, or improperly construct the product is not covered by this warranty.